

SCHOTTKY BARRIER RECTIFIER

VOLTAGE RANGE: 20 --- 200 V
CURRENT: 10.0A

FEATURES

- ◇ Metal-semiconductor junction with guard ring
- ◇ Epitaxial construction
- ◇ Low forward voltage drop, low switching losses
- ◇ High surge capability
- ◇ For use in low voltage, high frequency inverters free wheeling, and polarity protection applications
- ◇ The plastic material carries U/L recognition 94V-0

MECHANICAL DATA

- ◇ Case: JEDEC ITO-220AC, molded plastic
- ◇ Terminals: Axial lead, solderable per MIL-STD-750, Method 2026
- ◇ Polarity: As marked
- ◇ Weight: 0.08 ounces, 2.24 grams
- ◇ Mounting position: Any

ITO - 220AC

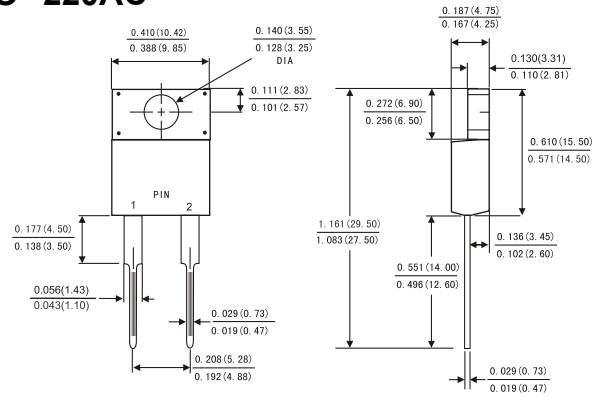

Dimensions in inches and (millimeters)

MAXIMUM RATINGS AND ELECTRICAL CHARACTERISTICS

Ratings at 25°C ambient temperature unless otherwise specified.

Single phase, half wave, 60 Hz, resistive or inductive load. For capacitive load, derate by 20%.

	Symbols	MBRF 1020	MBRF 1030	MBRF 1040	MBRF 1050	MBRF 1060	MBRF 1080	MBRF 10100	MBRF 10150	MBRF 10200	Units
Maximum repetitive peak reverse voltage	V_{RRM}	20	30	40	50	60	80	100	150	200	Volts
Maximum RMS voltage	V_{RMS}	14	21	28	35	42	56	70	105	140	Volts
Maximum DC blocking voltage	V_{DC}	20	30	40	50	60	80	100	150	200	Volts
Maximum average forward rectified current (see Fig.1)	$I_{(AV)}$	10.0									Amps
Peak forward surge current 8.3ms single half sine-wave superimposed on rated load (JEDEC method)	I_{FSM}	150.0									Amps
Maximum instantaneous forward voltage at 10.0 A (Note 1)	V_F	0.60		0.75		0.85		0.90		0.95	Volts
Maximum instantaneous reverse current at rated DC blocking voltage (Note 1)	$T_A = 25^\circ\text{C}$	0.2									mA
	$T_A = 125^\circ\text{C}$	15			50						
Typical thermal resistance (Note 2)	$R_{\theta JC}$	2.5									°C/W
Operating junction temperature range	T_J	-65 to +150									°C
Storage temperature range	T_{STG}	-65 to +150									°C

- NOTE: 1. Pulse test: 300us pulse width, 1% duty cycle.
2. Measured at 1.0MHz and applied reverse voltage of 4.0V DC.
3. Thermal resistance junction to ambient

FIG.1-FORWARD CURRENT DERATING CURVE

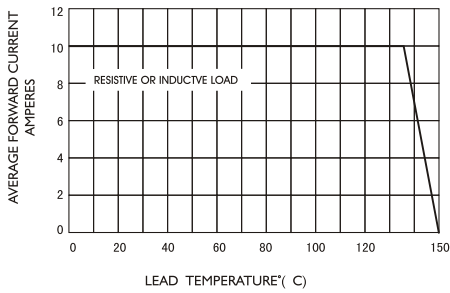

FIG.2-MAXIMUM NON-REPETITIVE PEAK FORWARD SURGE CURRENT

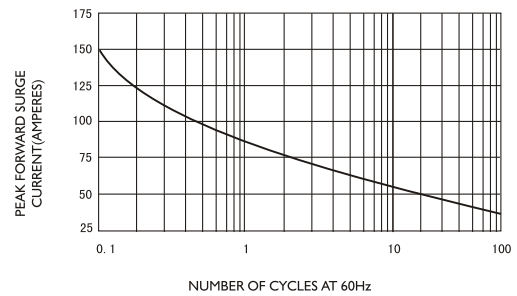

FIG.3-TYPICAL INSTANTANEOUS FORWARD CHARACTERISTICS

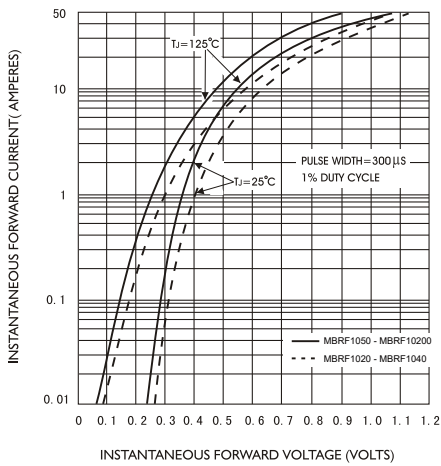

FIG.4-TYPICAL REVERSE CHARACTERISTICS

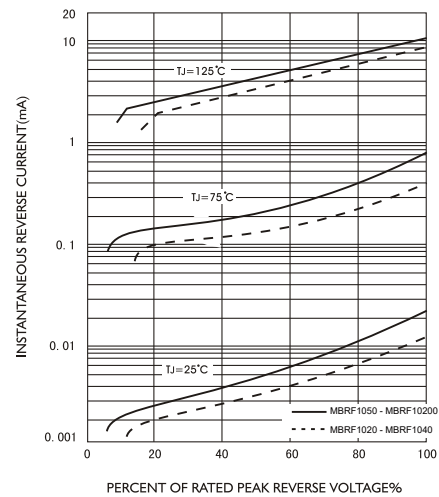

FIG.5-TYPICAL JUNCTION CAPACITANCE

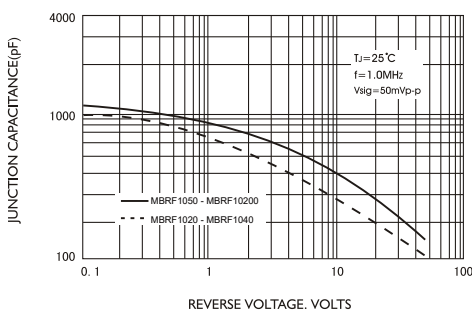

FIG.6-TYPICAL TRANSIENT THERMAL IMPEDANCE

